



INSTALLATION DRAWING

ACO Polycrete Pty Ltd
1300 765 226
sales@acoaus.com.au

DRG #: IT005
www.acostainless.com.au
www.acostainless.co.nz

SYSTEM CHANNEL, SUSPENDED SLAB, VINYL SEAL PROFILE, VINYL FINISH FLOORING

ACO Limited
0800 448 080
sales@aconz.co.nz

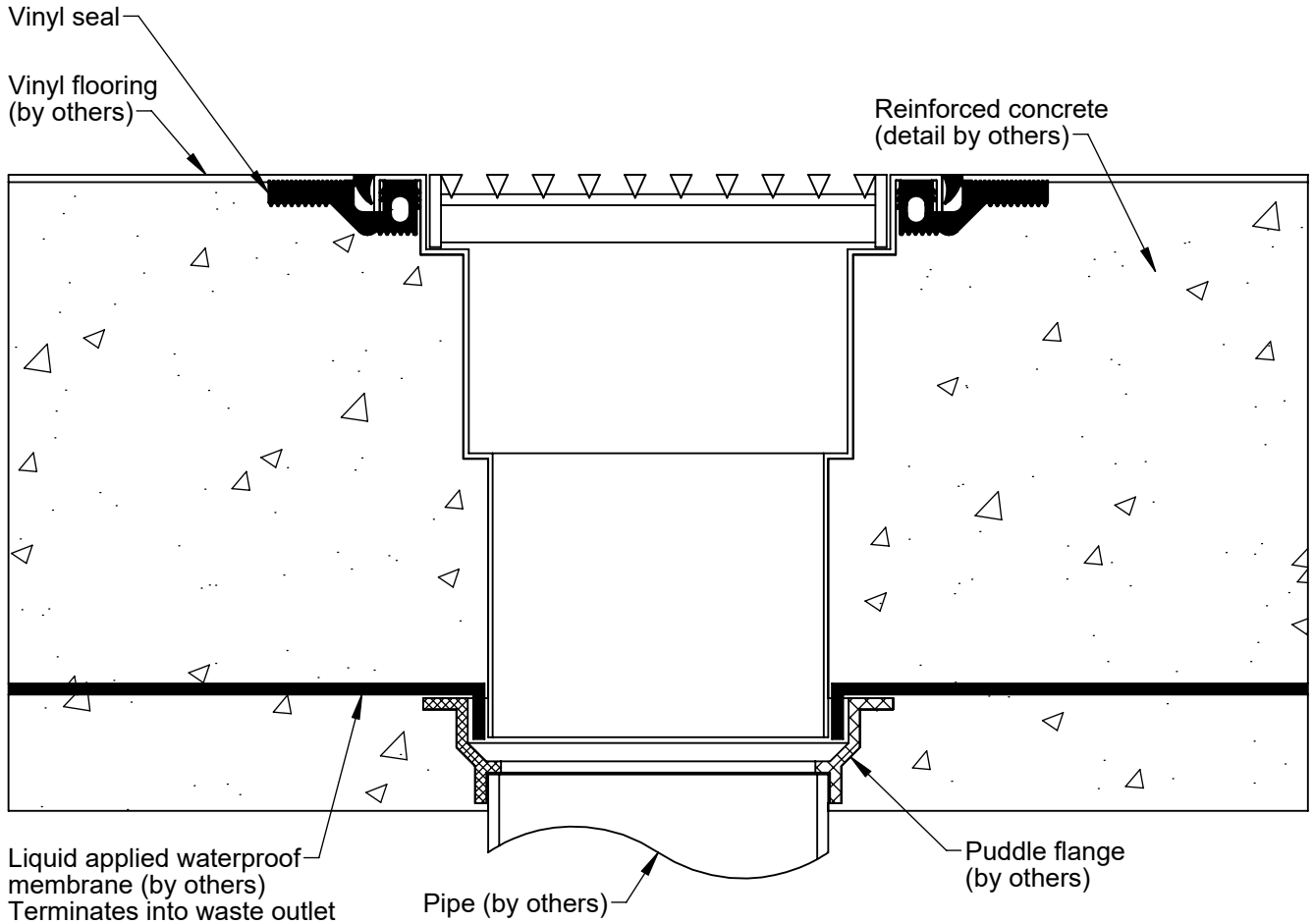

NOTES:

1.. These details only provide a practical reference. ACO recommends designers and installers check local legislative standards and practices, or seek specialised engineering advice.

Specification Clause

The floor drain channels are to be ACO Stainless **System 100/200/300*** grade **304/316** stainless steel as supplied by ACO Polycrete Pty Ltd. All components used within the scope of the systems are shown on Drawing Number/s: _____*. All work should be carried out strictly in accordance with the manufacturer's instructions and the installation details set out on Drawing Number/s: _____*.

All components are to be supplied with **constant depth/sloped** channels with vinyl seal edge to suit vinyl flooring. The channels overall depth and length, position and nominal size of outlet specified on Drawing Number/s: _____*.

Grates are to be part number _____*, **with/without** locking devices.

*Please delete or complete where appropriate